

## MODEL OF HYDRAULIC SINGLE-ACTING DRIVE FOR VALVES OF INTERNAL COMBUSTION ENGINE

Mariusz Smoczynski, Tomasz Szydłowski

*Technical University of Lodz*

*Department of Mechanical Engineering*

*Zeromskiego 116, 90-924 Lodz, Poland*

*tel. +48 42 6312390, fax: +48 42 6312398*

*e-mail: mariusz.smoczynski@p.lodz.pl, tomasz.szydowski@p.lodz.pl*

### **Abstract**

*This paper shows the conception and the model of hydraulic single-acting valve drive for internal combustion engines. This drive should give free control for valve lift, valve opening and valve closing time. It consists of parts: electric control valve and hydraulic actuator, whose piston is connected with engine valve and return spring. One of the basic components of high pressure HEUI injector for the Diesel engine – electric valve with solenoid was chosen as electric control valve. Principle of operation, physical and mathematical model of this drive is to be presented in this paper. Presented model consists of electrical, mechanical and hydraulic subsystems: slide of control valve with solenoid coil, power piston of hydraulic actuator with return spring and hydraulic components.*

*Describe the dynamic behaviour of the solenoid was based on non-linear magnetic circuit model. Movement of valve slide and power piston of actuator was based on the motion equation. Description of hydraulic subsystems was based of one-dimensional, compressible flow model. After full system identification basic parameters of this drive (like supply oil pressure or valve lift) will be calculated and analyzed for better load exchange in internal combustion engines.*

**Keywords:** road transport, simulation, internal combustion engines, hydraulic drive, camless valve drive

### **1. Introduction**

The first works and analysis about hydraulic drive for valves of internal combustion engines shows that in this drive valve opening time should be up to 3 ms and supply oil pressure for hydraulic actuator should be from 10 to 15 MPa [5, 6]. Hydraulic single-acting drive was taken into consideration. One of basic components of high pressure HEUI injector for the Diesel engine – electric valve with solenoid was taken into consideration as control valve. For next investigations and analysis the model of the hydraulic drive with this electric control valve should be prepared.

### **2. Conception of hydraulic single-acting valve drive**

The conception of hydraulic single-acting valve drive for internal combustion engines was shown in Fig. 1. Single-acting hydraulic actuator 9 is the basic element of this drive, which opens the engine valve 10. Return spring closes the engine valve. Operation of the supply oil is realized by electrovalve 8 (connects actuator with supply or with tank). There are other elements: tank 1, supply pump 2, filter 3, safety valves 4, cooler 7 and hydropneumatic accumulator 6 used to reducing of the supply oil pressure fluctuation.

### **3. Structure and operation of electric control valve**

One of basic components of high pressure HEUI injector for the Diesel engine – electric valve with solenoid (see Fig. 2) was taken into consideration as one of possible control electrovalve.

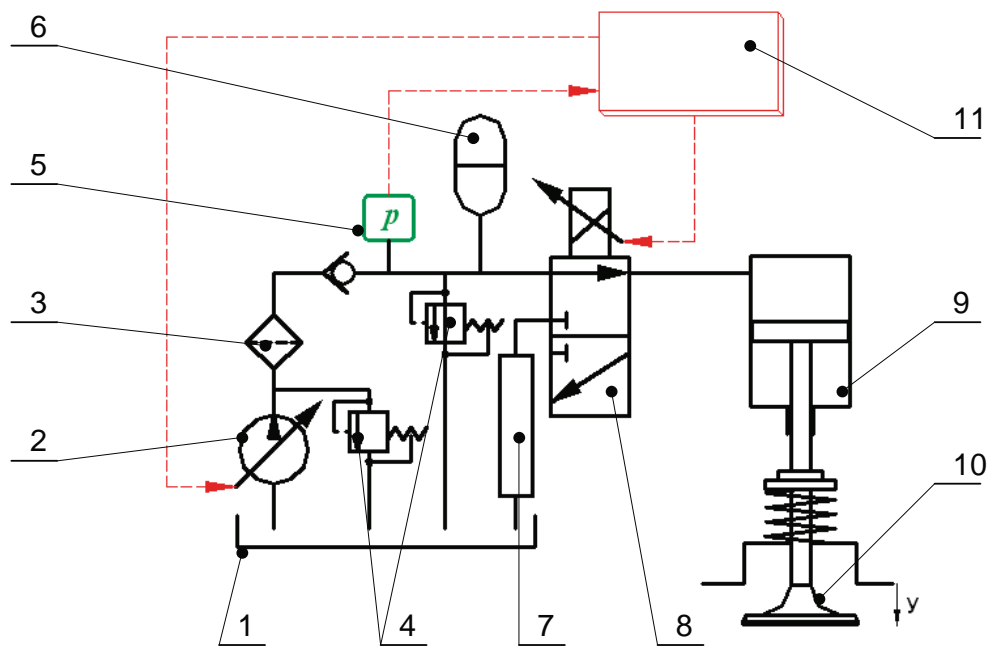

Fig. 1. The conception of hydraulic single-acting valve drive: 1 – tank, 2 – pump, 3 – filter, 4 – safety valves, 5 – pressure sensor, 6 – hydro-pneumatic accumulator, 7 – cooler, 8 – electrovalve, 9 – actuator, 10 – engine valve, 11 – control unit

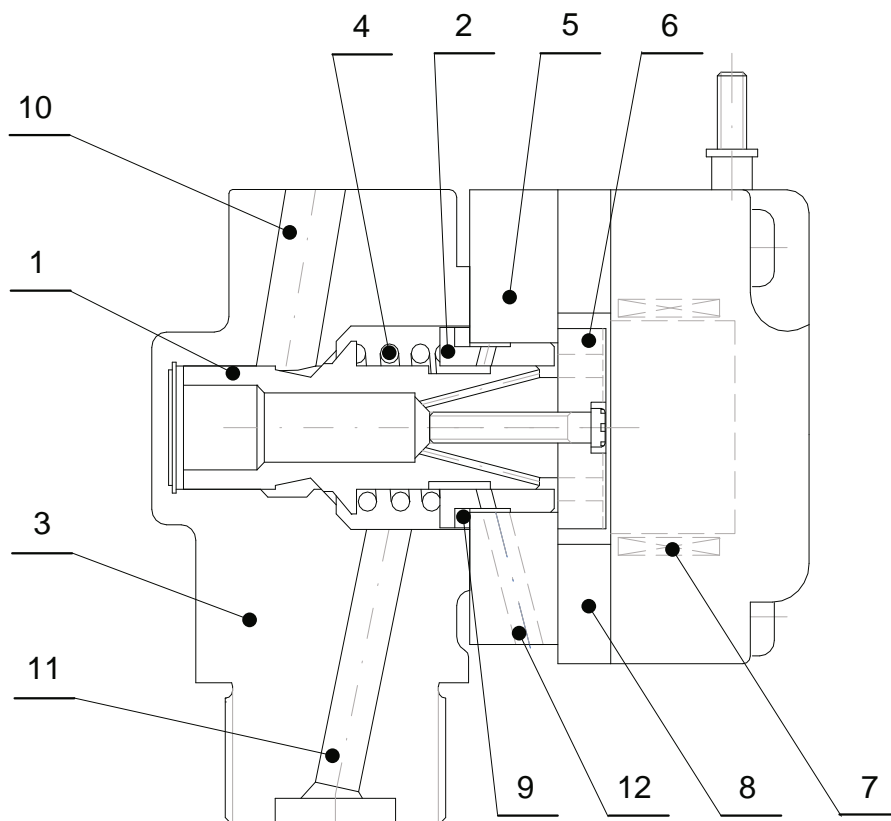

Fig. 2. The structure of Caterpillar electrovalve [1,7]: 1 – slider, 2 – sleeve, 3 – body, 4 – spring, 5 – mounting, 6 – plunger, 7 – solenoid coil, 8 – spacer washer, 9 – shim, 10 – supply port, 11 – outlet port, 12 – return port

This injector is supplied with engine oil on pressure from 4 to 21 MPa [1, 7]. The principles of operation were shown in Fig. 3.

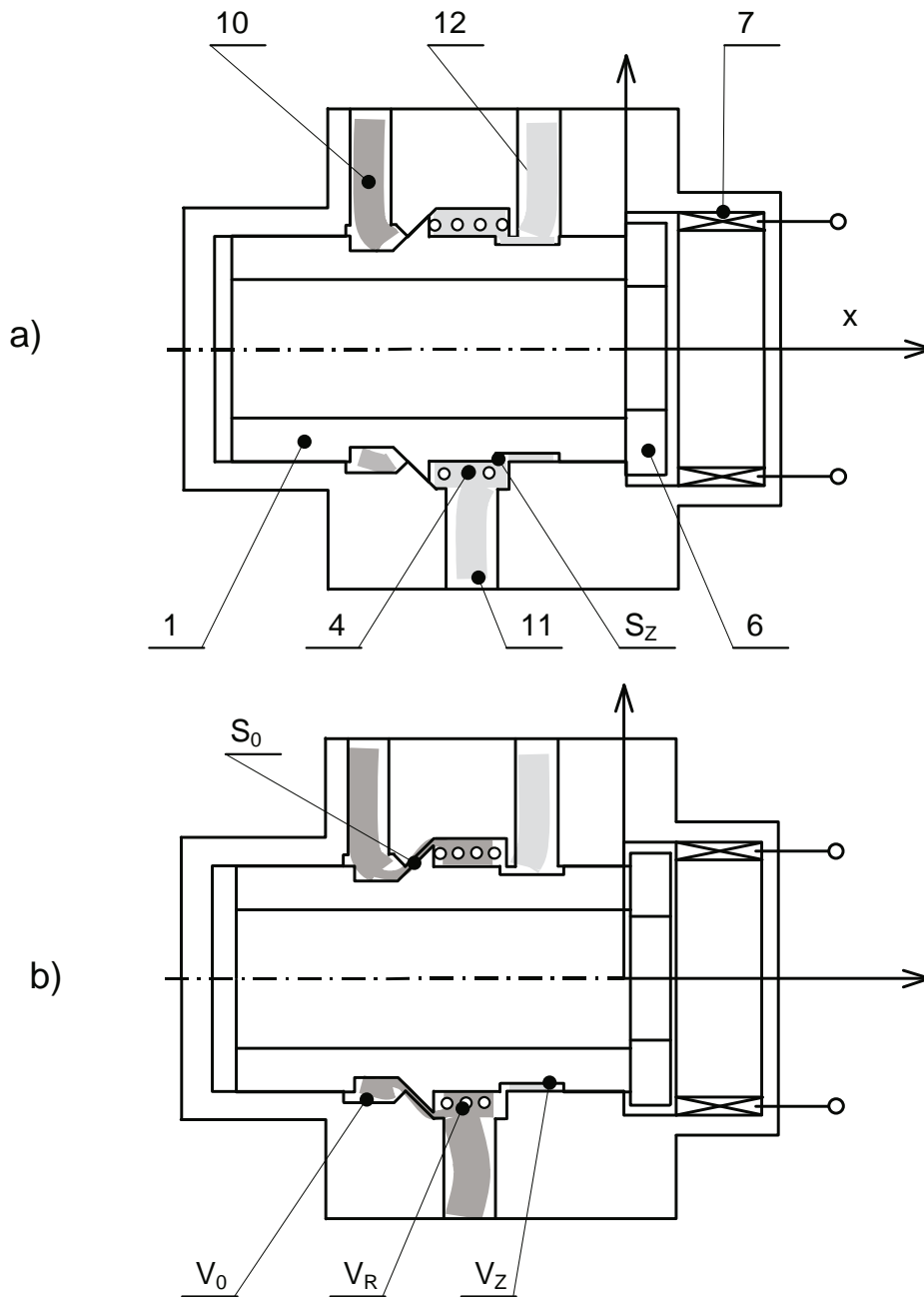

Fig. 3. The operating of Caterpillar electrovalve: a – null position (closed), b – work position (open), V – volumes, S – orifices, indexes: 0 – supply, R – outlet, Z – return

After turning on the control voltage to the solenoid coil 7, solenoid plunger 6 with slider of control valve 1 moves right and connects supply port 10 with outlet port 11 by working chamber  $V_R$ . Simultaneously the edge of slider 1 disconnects outlet port 11 from return port 12. This work position (control valve open) was shown in Fig. 3b. In this position supply oil pressure is turned on to actuator and engine valve is opened. After turning off the control voltage, return spring 4 moves slider 1 left, disconnects outlet port 11 from supply port 10 and simultaneously connects outlet port 11 with return port 12. Then the return spring closes the engine valve. This null position (control valve closed) was shown in Fig. 3a.

#### 4. Model of electric control valve

The structure and operation of electric control valve causes that control valve model consists of: electrical subsystem (solenoid 7), mechanical subsystem (slider 1 with solenoid plunger 6) and hydraulic system (chamber, ports and orifices).

##### Model of solenoid

Because of the short duration of the injection time if HEUI injectors, these solenoids are extremely fast. In addition, the dimensions of solenoid must be reduced. Therefore it is difficult to measure the magnetic characteristics and solenoid force. Cheung et al. model [2] was used to describe the dynamic behaviour of the solenoid. This is non-linear magnetic model. This model was used to modelling injectors of Diesel engines [3, 4].

Force and inductance of the solenoid can be expressed as:

$$F_e(x,i) = \frac{\mu_0 \cdot N^2 \cdot A \cdot i^2}{x^2} \quad (1)$$

$$L_e(x) = \frac{\mu_0 \cdot N^2 \cdot A}{\frac{l}{\mu_r} + x} \quad (2)$$

where:

- x - slider and plunger displacement,
- i - current,
- N - number of turns of solenoid coil,
- A - cross-sectional area,
- l - effective return magnetic path,
- $\mu_0$  - permeability of free space,
- $\mu_r$  - relative permeability.

The voltage equation is expressed as:

$$e = \frac{d(L_e(x) \cdot i)}{dt} + R \cdot i + K_b \cdot \frac{dx}{dt} \quad (3)$$

where:

R - resistance.

Last element represents the back emf voltage generated in the electrical circuit of the solenoid due to the movement of the steel plunger.

The force generated by the solenoid is proportional to the current:

$$F_e(x,i) = K_f(x) \cdot i \quad (4)$$

Both constants  $K_b$  and  $K_f$  are closely related and are numerically equal:

$$K_f(x) = K_b(x) \quad (5)$$

It allows to use  $K_b$  constant through experimentally measurement of  $K_f$  constant.

### Model of slider

The motion equation of the slider can be expressed as:

$$m_s \cdot \frac{d^2x}{dt^2} = F_e - F_{ts} \cdot \text{sign}\left(\frac{dx}{dt}\right) - k_s \cdot (x + x_0) - c_s \cdot \frac{dx}{dt} + F_{hs} \quad (6)$$

where:

- $m_s$  - mass of slider and plunger,
- $F_e$  - solenoid force,
- $F_{ts}$  - stiction force,
- $k_s$  - stiffness of the spring,
- $x_0$  - spring mounting lift,
- $c_s$  - viscosity friction coefficient,
- $F_{hs}$  - hydrodynamic force:

$$F_{hs} = \frac{0,72}{\sqrt{\xi}} \cdot \pi \cdot d_s \cdot x \cdot (p_0 - p_R), \quad (7)$$

where:

- $\xi$  - hydrodynamic resistance coefficient,
- $d_s$  - slider diameter,
- $p_0$  - pressure of supply,
- $p_R$  - pressure of outlet.

### Model of hydraulic components

For the model of hydraulic components of the drive, the following assumptions were applied:

- working oil do not change of physical properties (temperature is not changed, no air is present),
- inlet pressure is equal to supply pressure and constant,
- return pressure is equal to atmospheric pressure (due to conduits with large diameters),
- resistance of flow is small (due to big work pressure),
- speed of pressure propagation is infinite - related events are simultaneous (due to short distances and big pressure wave propagation speed),
- no oil leakage between the components,
- walls expansion is not taken into consideration,
- oil compressibility is taken into consideration.

With these assumptions, a one-dimensional, transient and compressible flow model of the hydraulic components of the drive can be used. Its structure is based on mass conservation.

Fig. 4 shows hydraulic components of operation valve. There is supply pressure  $p_0$  in supply port. Outlet port 10 connects with working chamber (pressure  $p_R$  and volume  $V_R$ ). There is atmospheric pressure  $p_z$  in return port 12. Supply port 10 connects with working chamber by coned seat (cross-sectional area  $S_0$  – changes with displacement of slider). Return port 12 connects with working chamber by cylinder orifice (cross-sectional area  $S_Z$  – changes with displacement of slider). In null position of the electrovalve (see Fig. 3a) coned seat orifice  $S_0$  is closed and cylinder orifice  $S_Z$  is opened to a maximum. During opening of the electrovalve this situation changing: coned seat orifice  $S_0$  is opened up to a maximum and cylinder orifice  $S_Z$  is closed. Changes of cross-sectional area of orifices may be expressed by equations:

$$S_0(x) = \pi \cdot x \cdot \sin(\alpha_0) \cdot [D_0 + x \cdot \sin(\alpha_0) \cdot \cos(\alpha_0)], \quad (8)$$

$$S_Z(x) = \pi \cdot D_Z \cdot (x_{\max} - x), \quad (9)$$

where:

D - diameter of the orifice,

$\alpha$  - angle of coned seat.

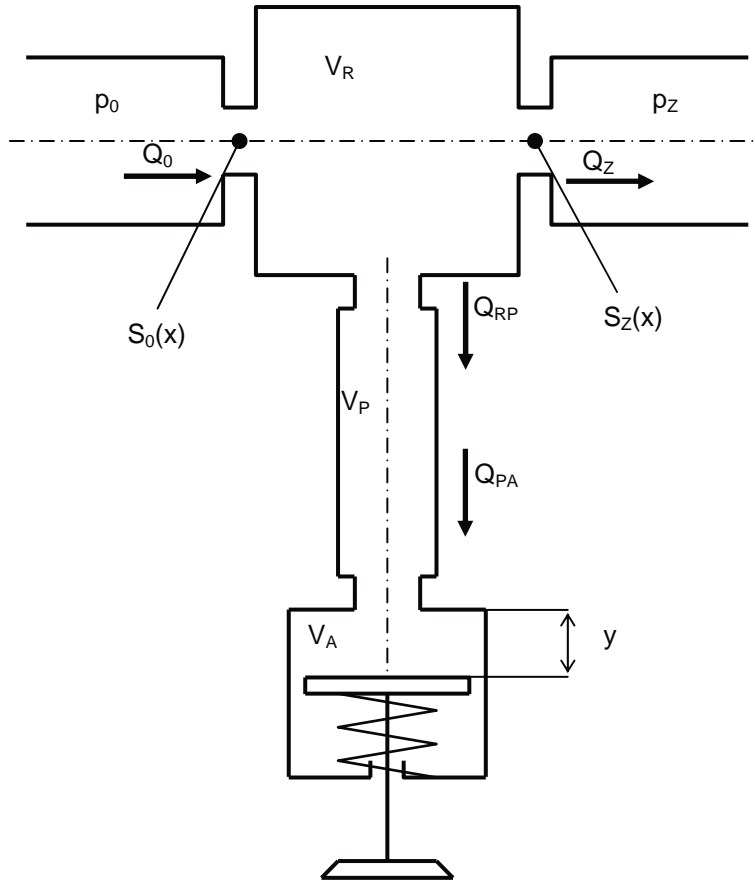

Fig. 4. Hydraulic diagram of single-acting valve drive: V – volumes, P – pressures, S – orifices, Q – flowrates, indexes: P – conduit, A – actuator, 0 – supply, R – outlet, Z – return

The oil flowrate through the orifices of electrovalve may be expressed as:

$$Q_0 = K_0 \cdot S_0(x) \cdot \sqrt{p_0 - p_R}, \quad (10)$$

$$Q_Z = K_Z \cdot S_Z(x) \cdot \sqrt{p_R - p_Z}, \quad (11)$$

where:

K - flow coefficient,

p - pressures before and after orifice.

The transient flowrate associated with oil compressibility (in the work chamber  $V_R$ ) may be compared with other flowrate and may be expressed as:

$$Q_{ER} = \frac{V_R}{E} \cdot \frac{dp}{dt}, \quad (12)$$

where:

E - oil bulk modulus (is a function of pressure).

The mass conservation equation for the working chamber of the electrovalve shows that inlet flowrate causes return flowrate, outlet flowrate to actuator  $Q_{RP}$  and acts on the oil in the volume of working chamber:

$$Q_0 = Q_Z + Q_{RP} + Q_{ER} \quad (13)$$

## 5. Model of actuator

Outlet flowrate from electrovalve acts and moves power piston of actuator with the engine valve. The structure and operation of actuator causes that its model consists of: mechanical subsystem (power piston with return spring) and hydraulic subsystem (actuator chamber).

### Model of power piston

The motion equation of the power piston can be expressed as:

$$m_A \cdot \frac{d^2y}{dt^2} = A_A \cdot p_A - F_{tA} \cdot \text{sign}\left(\frac{dy}{dt}\right) - k_A \cdot (y + y_0) - c_A \cdot \frac{dy}{dt} + m_A \cdot g - F_G, \quad (14)$$

where:

$m_A$  - mass of power piston and engine valve,  
 $A_A$  - area of power piston,  
 $p_A$  - actuator pressure,  
 $F_{tA}$  - stiction force,  
 $k_A$  - stiffness of the spring,  
 $y$  - power piston displacement,  
 $y_0$  - spring mounting lift,  
 $c_A$  - viscosity friction coefficient,  
 $F_G$  - gas force acting on the engine valve head:

$$F_G = A_G \cdot p_G(t), \quad (15)$$

where:

$A_G$  - area of engine valve head,  
 $p_G$  - gas pressure in engine cylinder liner.

### Model of hydraulic components

The outlet flowrate from electrovalve affects on the oil volume and moves the piston – engine valve set. The mass conservation equation for the actuator chamber can be expressed as:

$$Q_{PA} = Q_A + Q_{EA}, \quad (16)$$

where:

$Q_{PA}$  - inlet flowrate to actuator,  
 $Q_A$  - flowrate to moving piston – valve set,  
 $Q_{EA}$  - flowrate associated with oil compressibility in actuator chamber.

Flowrate to moving piston – valve set can be expressed as:

$$Q_A = A_A \cdot \frac{dy}{dt}. \quad (17)$$

Flowrate associated with oil compressibility in actuator chamber may is expressed by equation:

$$Q_{EA} = \frac{V_A}{E} \cdot \frac{dp}{dt}, \quad (18)$$

where:

$V_A$  - volume of actuator chamber:

$$V_A = A_A \cdot y. \quad (19)$$

## 6. Model of single-acting valve drive

The conduit connects both electrovalve and actuator. Inlet conduit flowrate is the outlet electrovalve flowrate  $Q_{RP}$ . Outlet conduit flowrate is the inlet actuator flowrate  $Q_{PA}$ . The mass conservation equation can be expressed as:

$$Q_{RP} = Q_{EP} + Q_{PA}, \quad (20)$$

where:

$Q_{EP}$  - flowrate associated with oil compressibility in conduit expressed by equation (12) for  $V_P$ .

Presented model of hydraulic single-acting valve drive is in identification phase. Its implementation is in MATLAB / SIMULINK environment.

## 7. Recapitulation

Presented model of the hydraulic single-acting engine valve drive allows building simulating model. Initial simulations are very promising. Calculated cross-sections-time for the kinematics of the engine valves is good in wide range of engine speed. Presented model is in identification phase. Verified model will allow calculating the basics parameters of the single-acting drive. It will allow analysing the influence of model parameters on its properties. This analysis will show necessary modifications and changes for better load exchange in internal combustion engines.

The specification of the simulation model, results of calculations and analysis will be shown in next papers.

Ministry of Science and Higher Education supports work as a research project NN509292835.

## References

- [1] Caterpillar Papers.
- [2] Cheung, N. C., Rahman, M. F., Lim, K. W., *Simulation and experimental studies towards the development of a proportional*, AUPEC'93, 1993.
- [3] Tran, X. T., Milton, B., White, T., Torrdon, M., *Modelling HEUI injector in MATLAB SIMULINK*, Proceedings of the 2003 IEEE/ASME International Conference on Advanced Intelligent Mechatronics (AIM 2003), Japan, 2003.
- [4] Tran, X. T., *Modelling and Simulation of Electronically Controlled Diesel Injectors. Thesis for the degree of Master of Engineering*, The University of New South Wales, Sydney, 2003.
- [5] Zbierski, K., Szydlowski, T., *Napęd hydrauliczny zaworu rozrządu tłokowego silnika spalinowego. Istota, możliwości, własne koncepcje – cz.I*, Napędy i Sterowanie, 10/2007.
- [6] Zbierski, K., Szydlowski, T., *Napęd hydrauliczny zaworu rozrządu tłokowego silnika spalinowego. Model i podstawowe parametry napędu jednostronnego działania – cz.II*, Napędy i Sterowanie, 7-8/2008.
- [7] Zbierski, K., *Tendencje w zasilaniu szybkoobrotowych silników o zapłonie samoczynnym*, Wydawnictwo Politechniki Łódzkiej, Monografie, Łódź, 1998.